

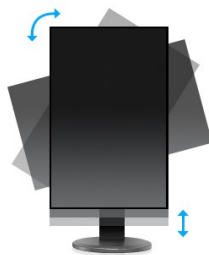

The ProLite B2280HS is a high specification 22" Full HD 1920 x 1080p LED-backlit monitor with Height Adjustability and Screen Rotation allowing you to set the perfect position of the screen ensuring ergonomic posture and optimal viewing comfort. 5msec black-to-black response time and 12 000 000 : 1 Advanced Contrast Ratio make the B2280HS ideal for Video Conferencing, DTP and CAD as well as the usual text based applications. Triple Input support of Analogue, DVI and HDMI ensures compatibility with the latest installed graphics cards and embedded Notebook outputs.

Available in black and white.



HAS + PIVOT

With a height adjustable stand you will create an ergonomic work posture and position that meets all health and safety requirements. This will not only prevent any health issues but will also increase your productivity. The pivot function allows the screen to rotate from landscape to portrait orientation. This functionality can be useful if the application requires more height than width.



SPEAKERS

This LED monitor is equipped with two high quality stereo speakers.

1. CARACTERÍSTICAS DE LA PANTALLA

DIAGONAL

21.5"; 54.7cm

RELACIÓN DE ASPECTO.	16 : 9
PANEL	TN LED, matte finish
RESOLUCION NATIVA	Full HD 1080p, 1920 x 1080 (2.1 megapixel)
BRILLO	250 cd/m ² típico
CONTRASTE ESTÁTICO	1000 : 1 typical
CONTRASTE AVANZADO	12 000 000 : 1 ACR
TIEMPO DE RESPUESTA	5ms
VIEWING ZONE	horizontal/vertical: 160° / 160° ; right/left: 80° / 80° ; up/down: 80° / 80°
COLOR DE LA PANTALLA	16.7 million
REDUCTOR DE LUZ AZUL	sí
ÁREA DE VISUALIZACIÓN H X W	268.11 x 476.64 mm; 10.6" x 18.8"
VIEWING ZONE CR>5	horizontal/vertical: 178° / 170° ; right/left: 89° / 89° ; up/down: 85 / 85°
PIXEL PITCH H X V	0.2482 x 0.2482 mm
SINCRONIZACIÓN HORIZONTAL	24 - 83kHz
VERTICAL SYNC	50 - 76Hz
SINCRONIZACIÓN	Separate sync

2. INTERFACES / CONECTORES / CONTROLADORES

CONECTOR DE ENTRADA ANALÓGICA	VGA
CONECTOR DE ENTRADA DIGITAL	DVI-D, HDMI
HDCP	yes

3. CARACTERISTICAS

APPLE - MAC	All iiyama monitors are compatible with Apple-Macintosh computers.
PLUG & PLAY	VESA DDC2B™
CONTROLES	Via OSD in 9 languages (EN, DE, FR, ES, IT, PT, Chinese, RU, JP) and 5 front controls (Power, Menu, + /Volume, - /ECO, Auto)
LOS CONTROLES DE USUARIO	luminance (contrast, brightness, ECO, i-style Colour, ACR), image steep (clock, phase, H. position, V. position, aspect), colour (gamma, colour temperature, sRGB), OSD setup (H. position, V. position, OSD time out, language), others (reset, signal select, audio input, OD, information), volume, auto adjust
ALTAVOCES	2 x 1 W (Stereo)
DISPOSITIVO ANTI-ROBO	Kensington-lock™ prepared
CERTIFICADOS	CE, TUV-GS, CU, TCO 6
SOPORTE DE ALTURA REGULABLE	Sí
AJUSTE DE ALTURA	130mm
ROTACIÓN (FUNCIÓN DE PIVOTE)	90°
SWIVEL STAND	320°; 160° left; 160° right
ÁNGULO DE INCLINACIÓN	22° up; 5° down

VESA MOUNTING	100 x 100 mm
COLOR	Blanco

4. ACCESORIOS

ACCESORIOS INCLUIDOS	power cable, DVI-D cable, audio cable, stand, screw, cable holder, quick start guide, safety guide
----------------------	--

5. GESTIÓN DE ENERGÍA

FUENTE DE ALIMENTACIÓN	AC100~240V 50/60Hz
UNIDAD DE FUENTE DE ALIMENTACIÓN	internal
CONSUMO DE ENERGÍA	21 W typical; max. 0.5 W in Power management mode
GESTIÓN DE ENERGÍA	VESA DPMS

6. ETIQUETA DE EFICIENCIA ENERGÉTICA DE LA UE

CLASE DE EFICIENCIA ENERGÉTICA	B
CONSUMO DE ENERGÍA EN MODO ENCENDIDO	23.8W
CONSUMO ANUAL DE ENERGÍA	35 kWh/annum*
LA PANTALLA EN DIAGONAL VISIBLE	55 cm; 21.5"; (22" segment)

This is information under Regulation (EU) No 1062/2010.

**Based on the power consumption of the television operating 4 hours per day for 365 days. The actual energy consumption will depend on how the television is used.*

7. EPEAT SILVER

EPEAT	EPEAT is a comprehensive environmental rating that helps identify greener computers and other electronic equipment. The Silver certification means the monitor meets all required criteria plus at least 50% of the optional requirements. EPEAT Silver is valid in countries where iiyama registers the product. Please visit www.epeat.net for the registration status in your country.
-------	--

8. DIMENSIONES / PESO

DIMENSIONES W X H X D	509.5 x 393 (523) x 244.5 mm
PESO	5.2 kg

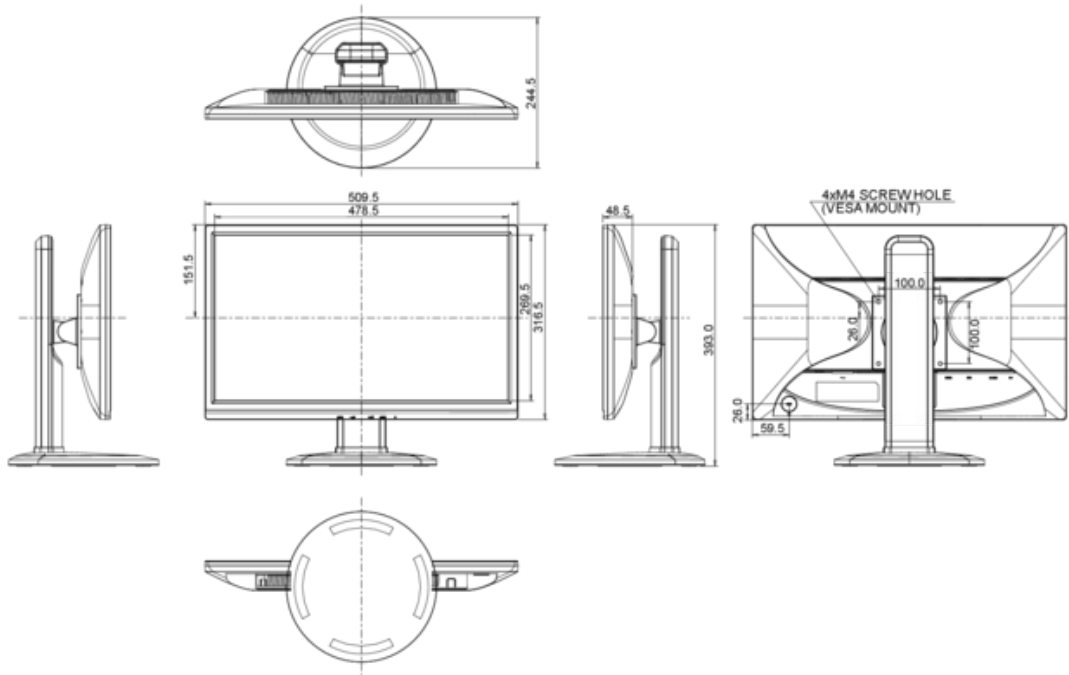

All trademarks and registered trademarks acknowledged. E & O E. Specification subject to change without notice. All LCD's comply with ISO-9241-307:2008 in connection with pixel defects.

© IIYAMA CORPORATION (). ALL RIGHTS RESERVED.